



SCHNEEBERGER
LINEAR TECHNOLOGY

MONORAIL AMS

Integrated Linear Distance
Measuring System

A complete package consisting of precision,
adjustment and service,
with significant design advantages



Reduction of the complexity and minimization of the process costs

With the
MONORAIL AMS
SCHNEEBERGER
is providing you
with a
complete product
with unique
advantages
with respect to
Precision
Installation
Adjustment
Service
Maintenance
Design and
Construction.

Precision

- ___ The expansion coefficient is the same as steel.
- ___ Good thermal coupling with the machine bed.
- ___ Measurement close to the working process.
- ___ Optimum alignment of the material measure as a result of the MONORAIL precision.
- ___ Vibration - and shock-resistant.
- ___ The generation of the material measure takes place on the finished, precise component.

Installation and adjustment

- ___ Delivered complete and ready for installation in accordance with the customer's specification.
- ___ No adjustment of the linear measurement is necessary.
- ___ Additional components and machining are not required.
- ___ Simple and easy installation - and adjustment process because of the integrated system ready for operation.

Service and maintenance

- ___ Consistent separation of all parts subject to wear from the guide carriage and the guide rail.
- ___ One measuring head for all MONORAIL sizes.
- ___ The most simple and precise possibility of changing by means of a central fixing screw.
- ___ The system is sealed against dust and liquids.
- ___ Chemically resistant against oils, grease, cooling media and cleaning agents.
- ___ Non-rusting execution of the material measure.
- ___ Protection of the material measure against effects of the environment and handling.
- ___ 100% interchangeable individual components.
- ___ Insensitive against all kinds of contamination with dirt.

Design and construction

- ___ Space-saving system, identical space requirements as for the MONORAIL profile rail guideway.
- ___ Several measuring heads on a single measuring ruler.
- ___ Short construction times, because no additional mechanical effort is necessary.
- ___ Short thermal stretches to the machine spindle.

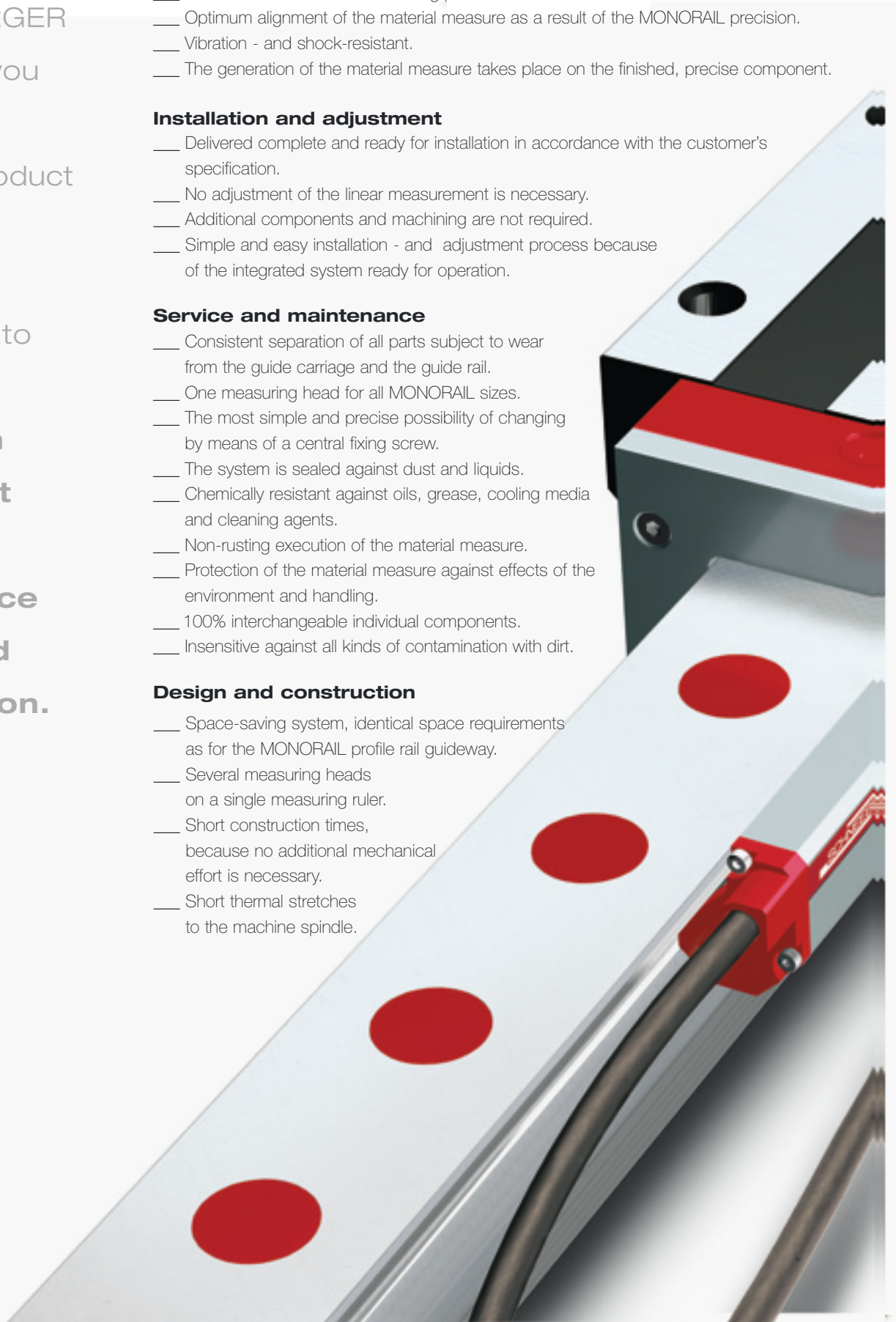

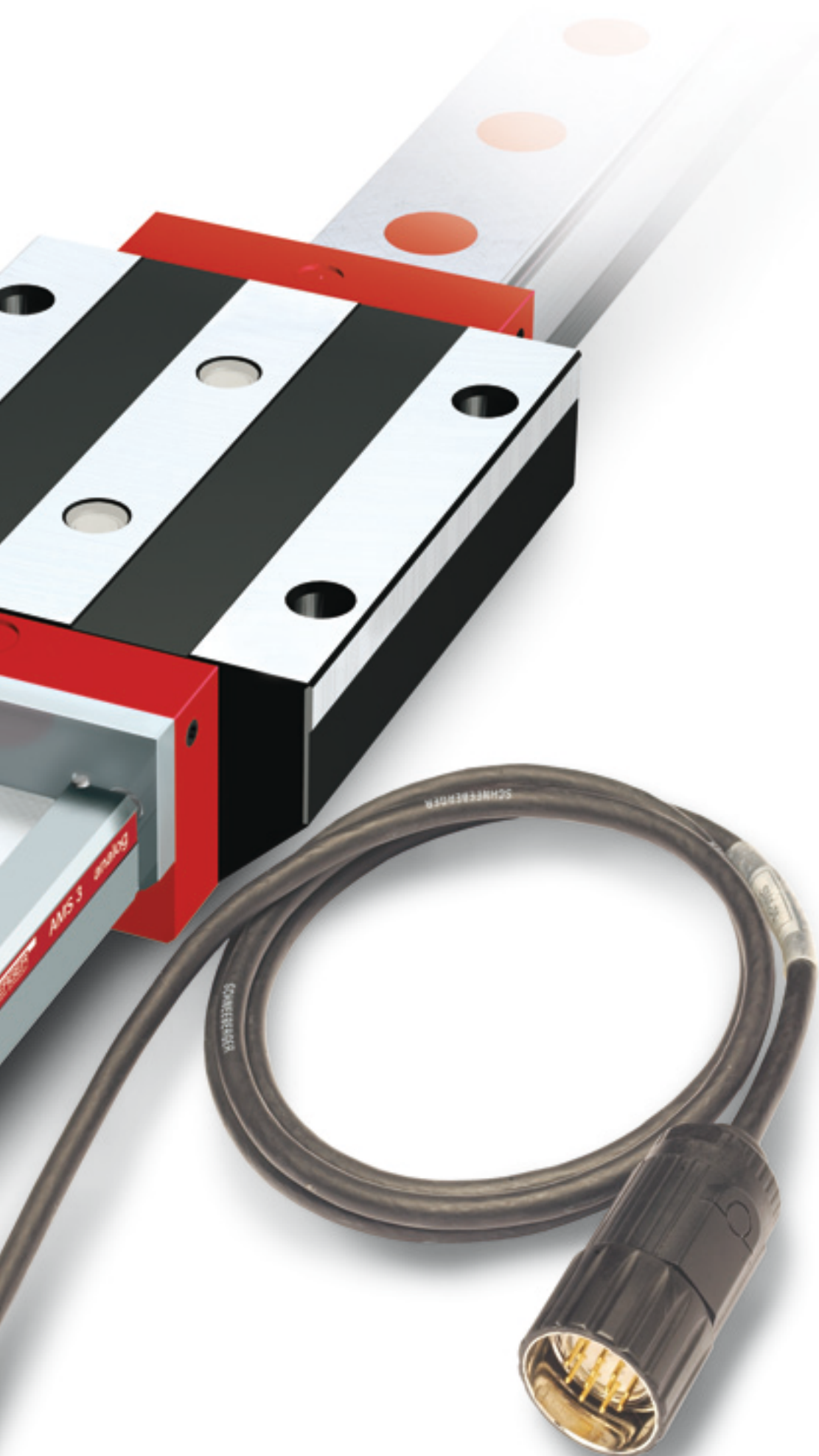

Description of the System and of the Function

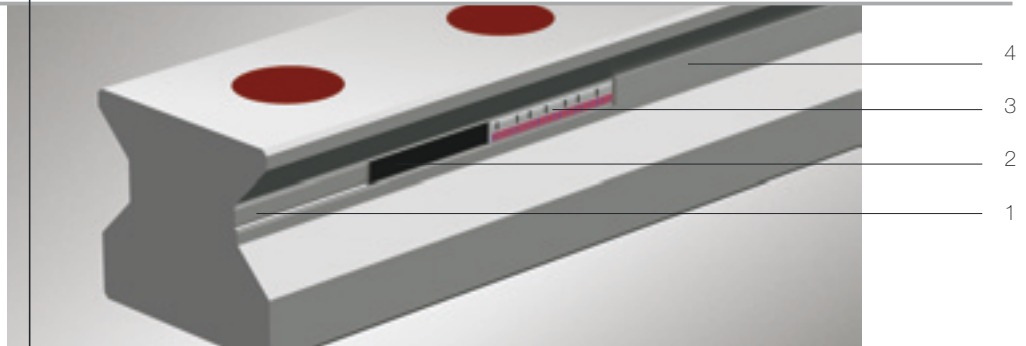

Rail with magnetised material measure

A groove is machined into the base of the MONORAIL rail (1).

After the adhesive fixing (2) and grinding of the magnetisable strip, the production of the material measure follows (3).

The exceedingly hard cover protects the magnetisation from subsequent change due to mechanical and magnetic environmental influences (4).

The measuring head consists of:

- Housing
- Measuring electronics
- Coupling spring made of titanium
- Longitudinal wipers
- Magneto-resistant sensor in the slider
- Ceramic wipers (Protection against solid particles)
- Transverse wipers (protection against liquids)
- Central fixing screw
- Measuring head cable with plug-type connector.

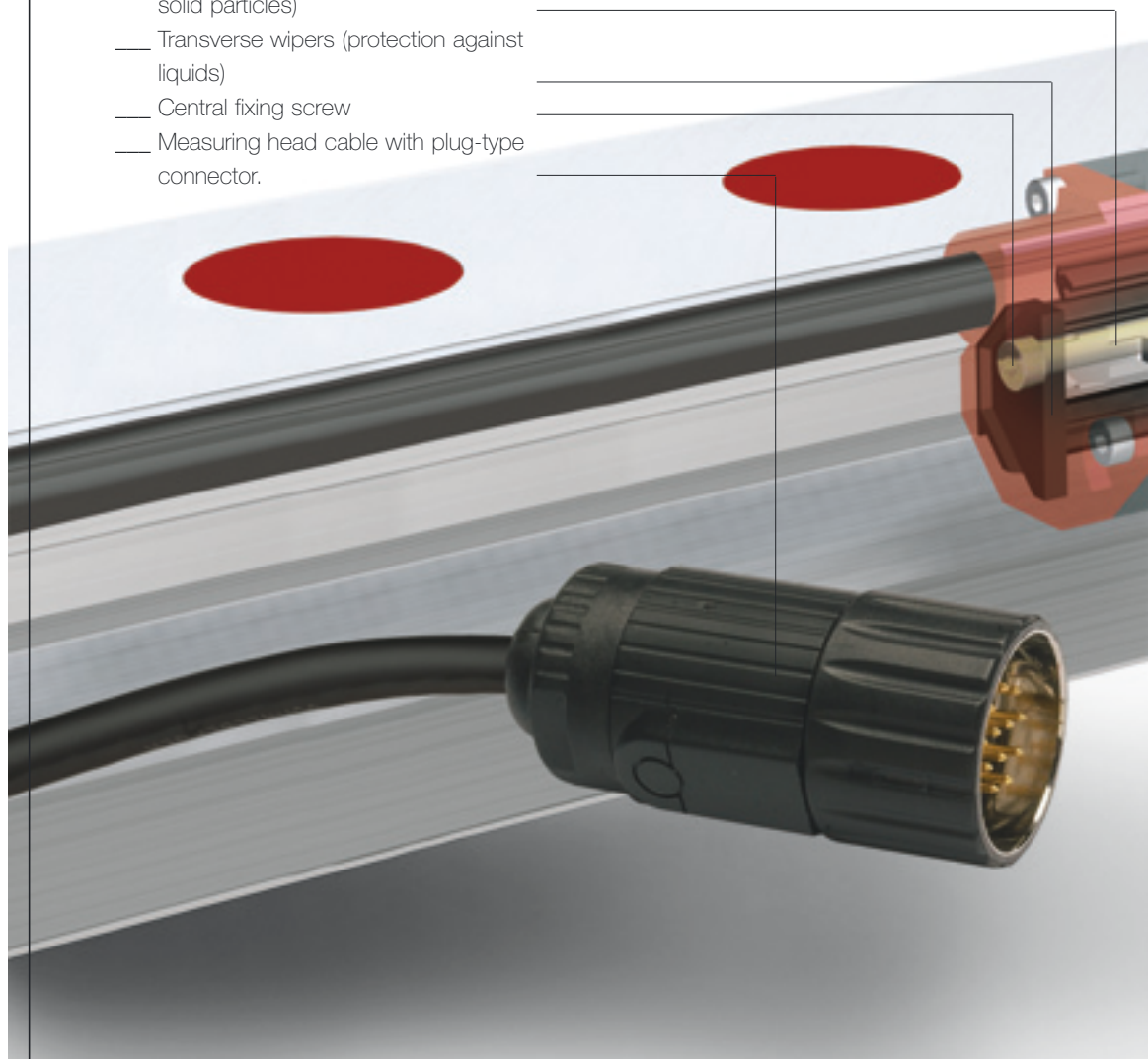

One measuring head for all sizes

Because the material measure is identically positioned relative to the upper guideway in the case of all MONORAIL sizes, a reading head can be universally utilised.

MR 65
MR 55
MR 45
MR 35
MR 25

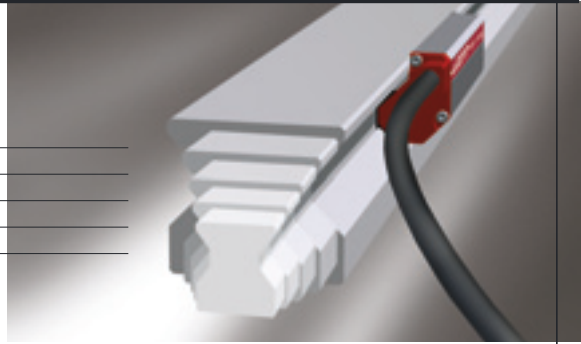

MONORAIL Carriages

The adapter plate (different for every size) is attached to the MONORAIL guide carriage with steel pins. It carries the 6-point bearing arrangement for the precise installation of the measuring head with the central tension bolt.

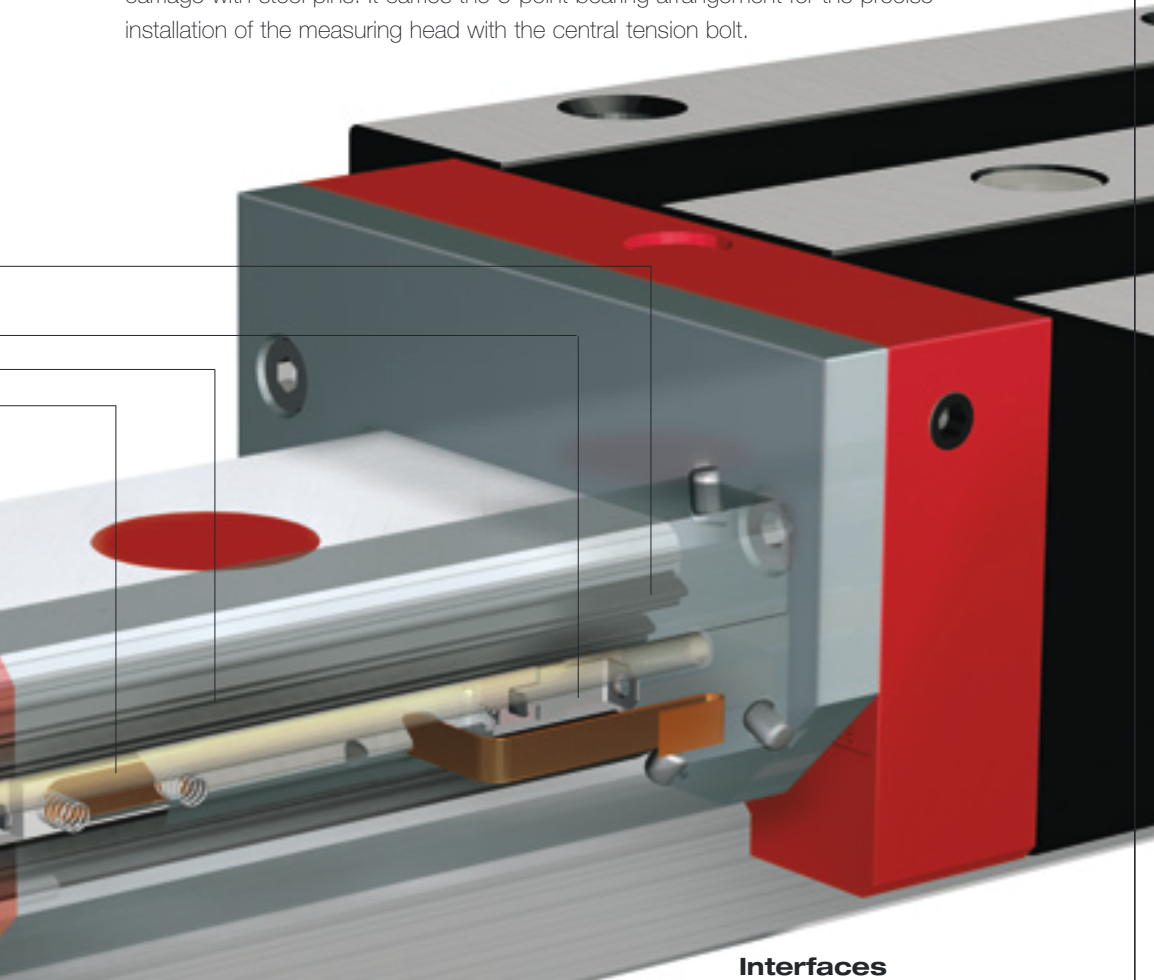

Interfaces

Designation	cable length	interface
SU	3 m with flange ring	1 Vss
RU	3 m with external thread	1 Vss
MU	0,3 m with mounting base	1 Vss

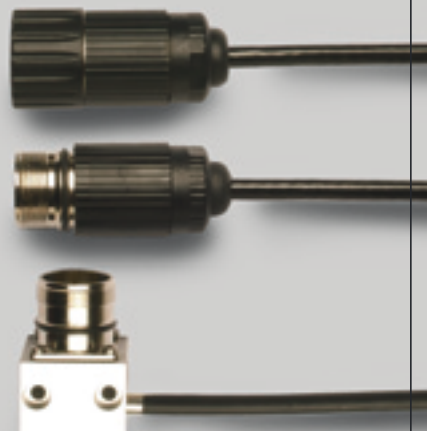

The highest reliability, minimum maintenance



Accuracy record

By means of the rail number (on every rail), SCHNEEBERGER makes possible the tracing of the system; as a result of this, the user has an accuracy record at his disposal.

Durable protection against environmental influences

The sealing system, which is redundant in longitudinal direction (wipers made of Viton and ceramic) durably protects the sensing system against oils, greases, cooling media and solid particle residues on the measuring strip.

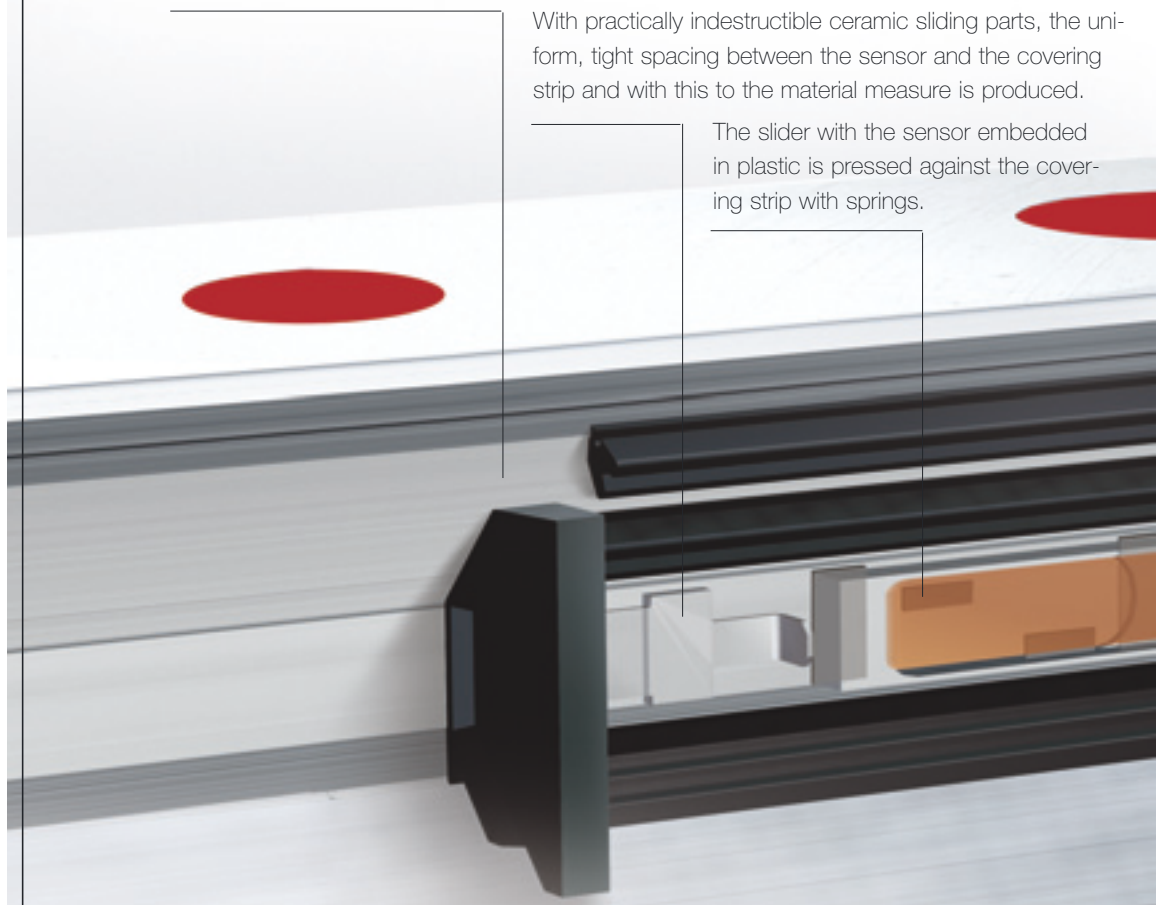

With practically indestructible ceramic sliding parts, the uniform, tight spacing between the sensor and the covering strip and with this to the material measure is produced.

The slider with the sensor embedded in plastic is pressed against the covering strip with springs.

Reliable scanning and maintenance-free accuracy

The MONORAIL rail and with this the material measure is fixed connected with the machine base body. The overall arrangement exactly follows the temperature course of the thermally inert masses and stabilises the machining process. The exceedingly low wear of the ceramic sliding surfaces in the slider has no influence on the precision. The reliable scanning produced by the small measuring gap is trouble-free due to its principle (the accuracy is not capable of being influenced by materials in the measuring gap). The accuracy is thus given right up to the end of the service life. Maintenance costs and maintenance work do not accrue. The modular design of the system makes possible the replacement of the measuring head without any adjustment being necessary.

Free of wear

The magnetic tape is glued into the bottom of the groove magnetically insulating and attached at its ends by means of spot welds. It is hermetically sealed with a non-wearing covering strip, which protects it from mechanical and chemical influences.

The covering strip forms the running surface for the sliders of the measuring head (the same hardness as the running surfaces of the rail). The measuring ruler can be cleaned if so required.

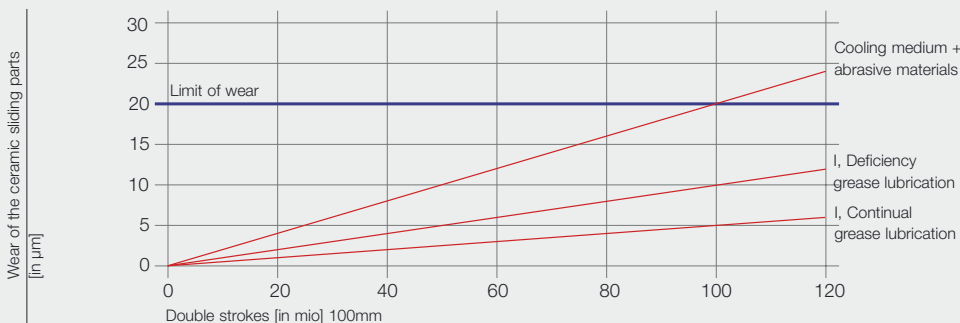
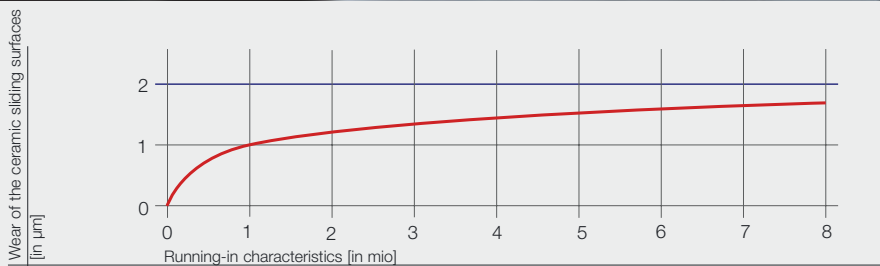
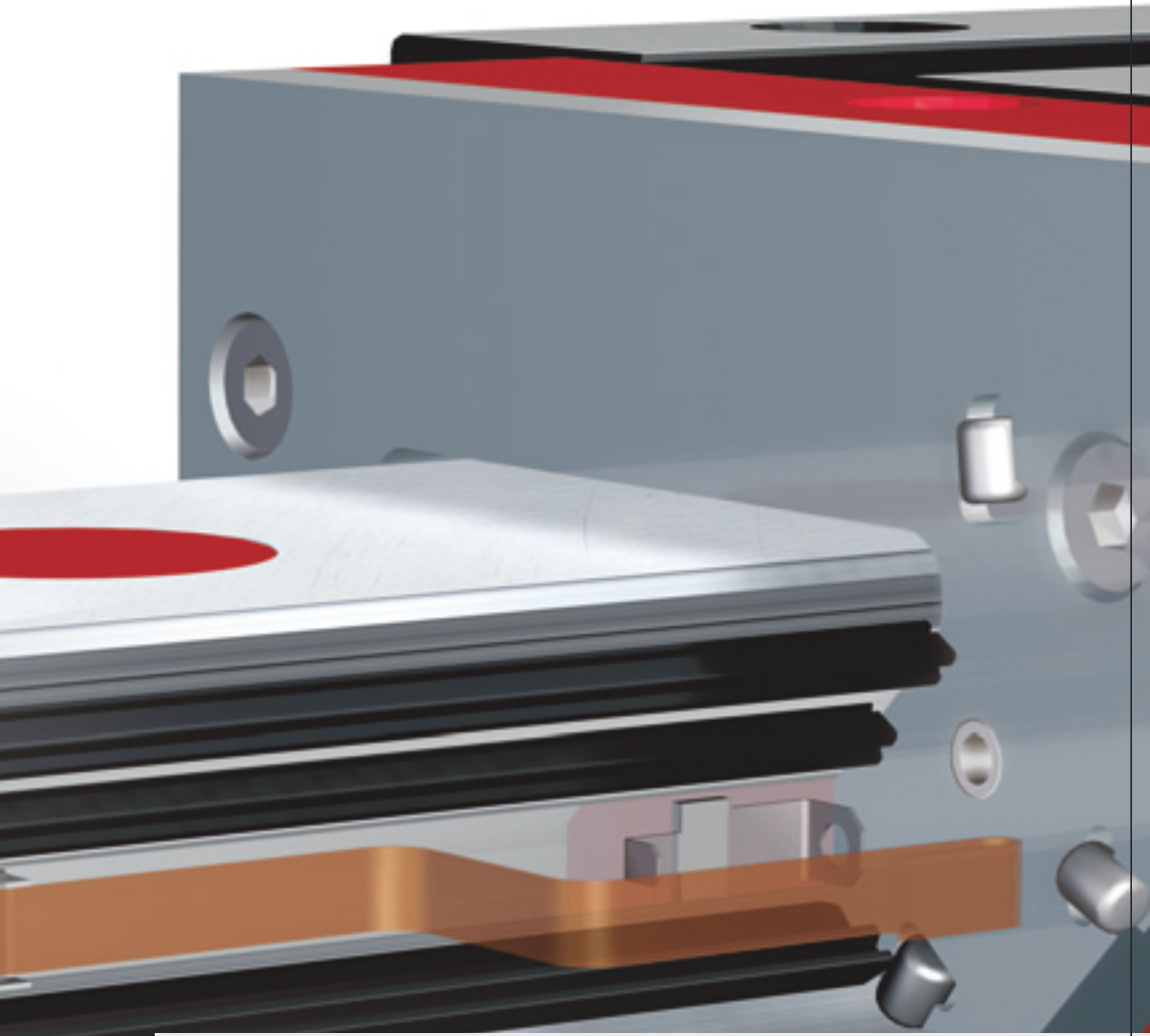

The measuring method

Establishment of the material measure

The measuring strip contains two magnetised tracks. The finely graduated incremental track consists of poles with a width of $200\mu\text{m}$, which are alternately arranged in longitudinal direction. The reference track for the determination of the absolute position is provided with distance-coded reference marks.

Magneto-resistive measuring principle

In case of a relative movement between the sensor and the material measure, the change in the field strength in the magneto-resistive sensor material leads to a well measurable change of the electric resistance. As a result of the electric circuit design of the sensor elements as a Wheatstone bridge, the interfering influences due to temperature fluctuations, aging and interfering fields are minimal.

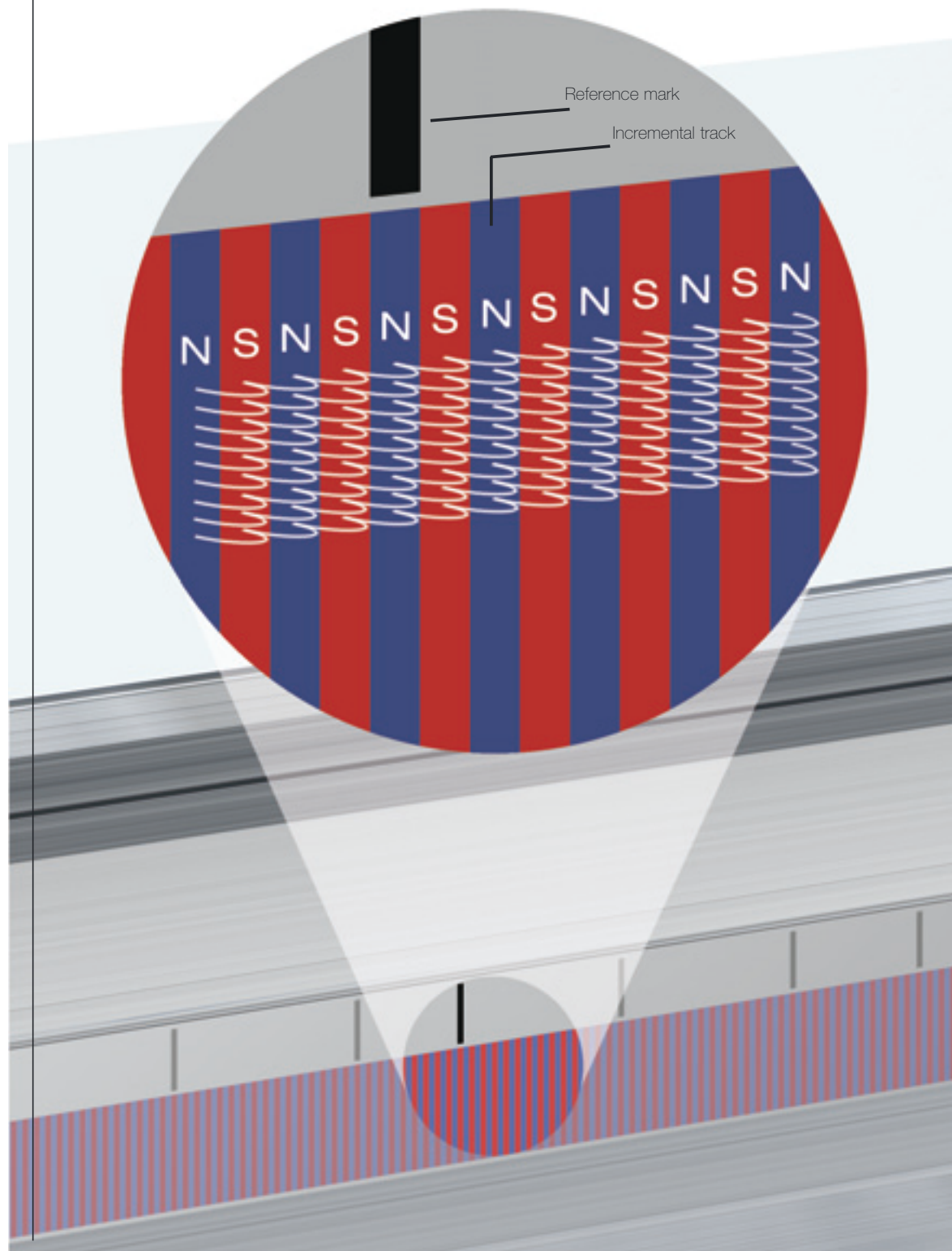

Construction of the sensor

Due to the arrangement of the sickle-shaped sensor elements, two sinus-shaped signals with a 90° phase shift are obtained from the incremental magnetisation. For the enhancement of the accuracy, the signals of 102 individual strips are averaged. Because the structure of the sensor is adapted to the magnetic graduation period, the influence of interfering magnetisations is strongly suppressed. The reference marks are implemented in triplicate for the exact definition of the switching flanks.

Processing of the measuring signals

The incremental sensor signals are conducted into high-performance driver stages through high-grade instrument amplifiers. Therefore stable signals capable of absorbing loads are available at the signal outputs.

The reference signals are digitally further processed and output as square wave signals. Already after passing over two reference marks the absolute position is known.

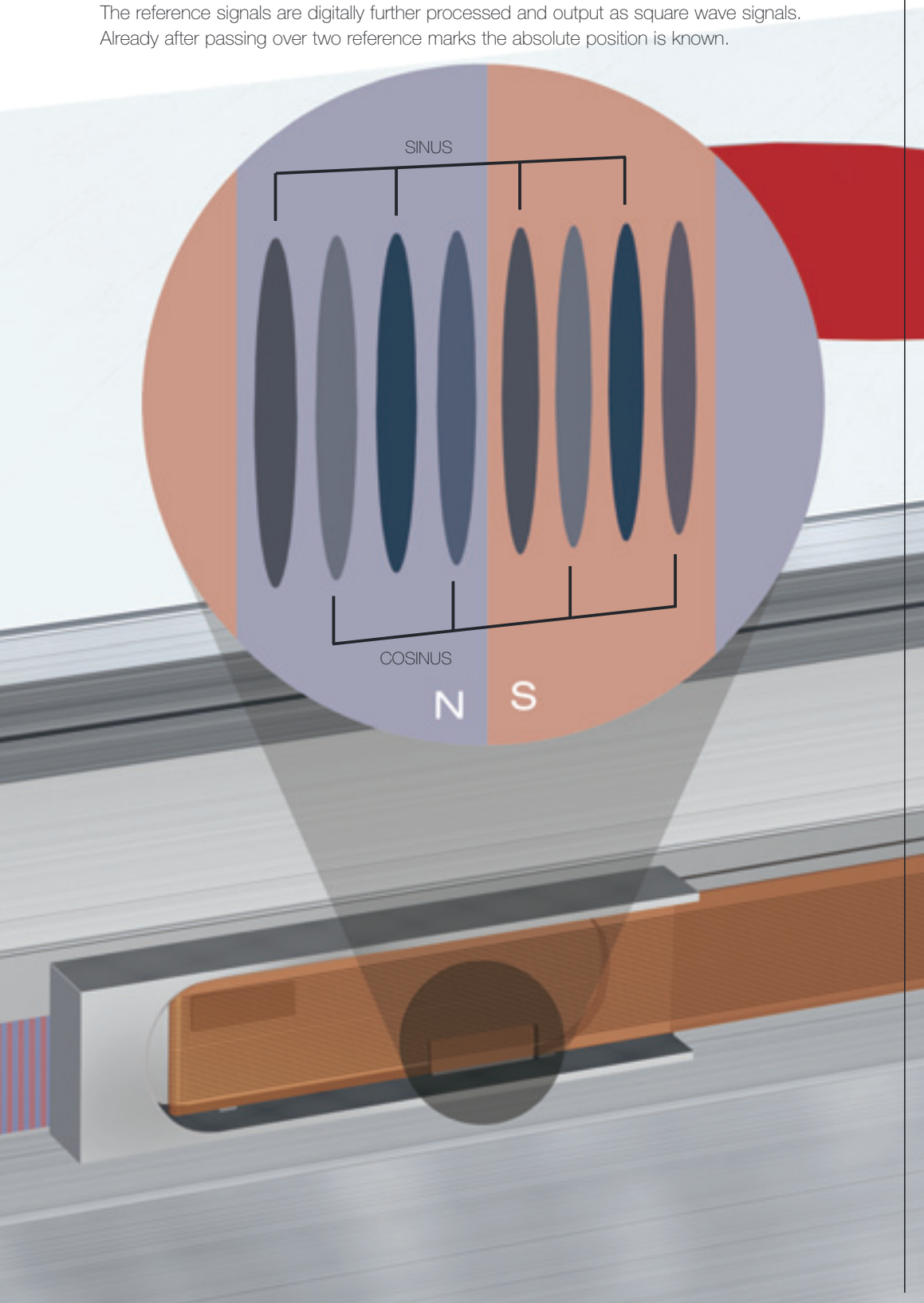

The measuring method

Automatic amplitude adjustment "AGC"

The current amplitude (represented by the periodic signals) is continually determined in the measuring electronics. In case of any deviations, the amplitude is adjusted. Therefore also in exceptional cases (installation error, external error, lifting-off of the slider), a standardised output signal is available.

Measuring deviations

As a result of the multitude of sensor strips used for the measurement, the user has a practically ideal measuring signal at his disposal. The accuracy of this technology has continually increased over the past years. SCHNEEBERGER is further increasing the precision of the overall system, this in order to be in a position to master the technical requirements in the future too.

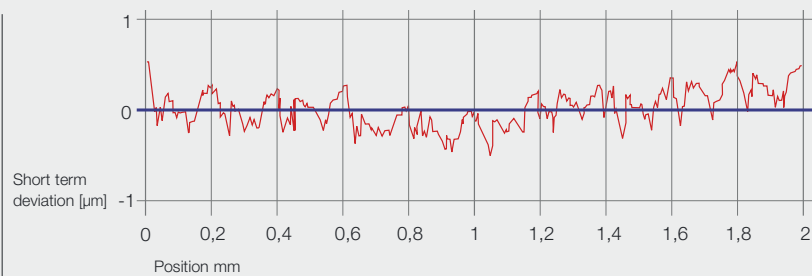

Resolution

The resolution limit of the system is situated at $0,05 \mu\text{m}$.

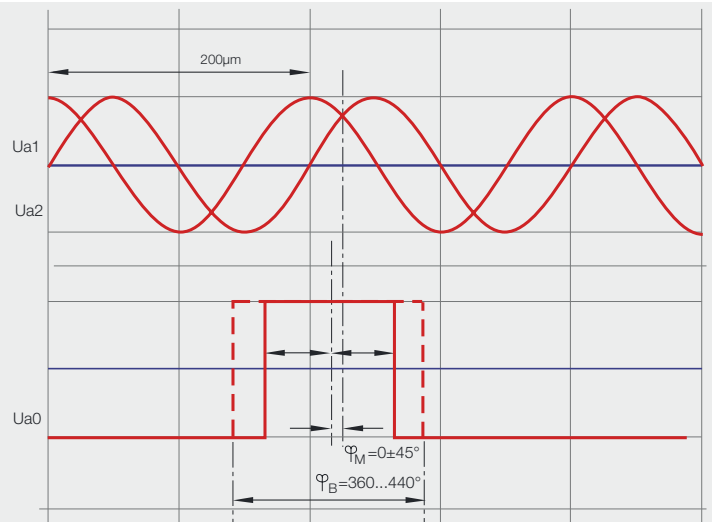

Positional independence of the sensor

All accuracy determining characteristics of the measuring signals (phase, amplitude differences, harmonic wave characteristics, etc.) are anchored in the sensor. Therefore even great positional deviations do not lead to an impairment of the signal quality: "The circuit remains stable." The direct consequences are a simple change of measuring heads without any adjustment needed, enhanced resistance against vibration and shocks as well as a broad tolerance band for the operation of the measuring heads.

SME_a Interpolation electronics

SCHNEEBERGER supplies high-performance interpolation electronics and a large range of connection – and extension cables for the connection of the measuring systems to control systems and metering counters.

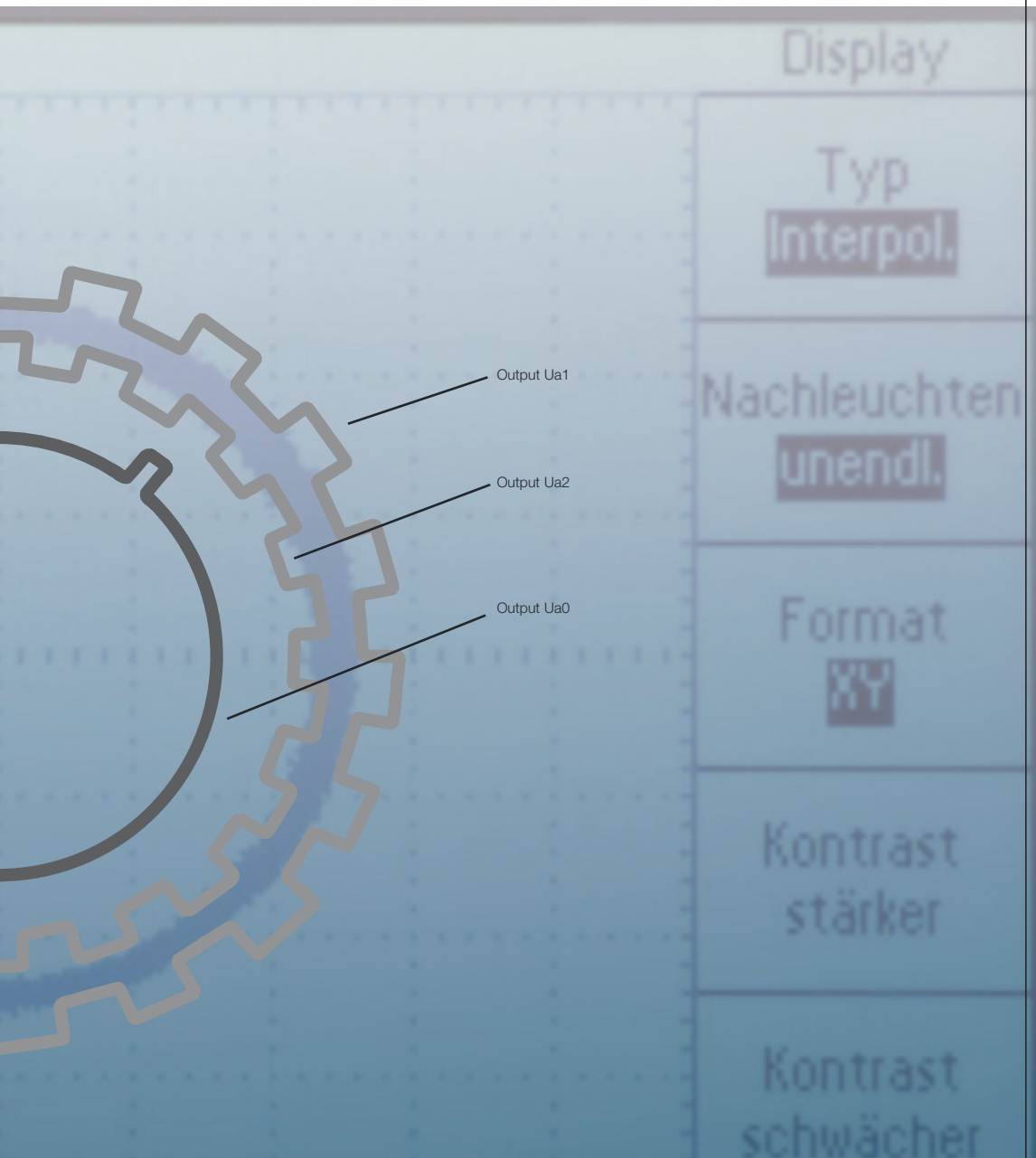

Electrical interface

Output signal	Sinus-shaped signals displaced by 90° 0,8 - 1,2 V _{SS} (120 Ω)
Reference signal	Square wave signal 1 V _{SS}
Electric power supply	+ 5 V \pm 5 %, max 60 mA

Technical data

System characteristics

Material measure	Hard magnetic periodic N-S division
Signal period	200 μm
Reference marks	every 50mm, distance-coded, customer-specific
Max. length	6000 mm

Accuracy

Accuracy class	+/- 5 $\mu\text{m}/1000 \text{ mm}$ / +/- 2 $\mu\text{m}/40 \text{ mm}$
Periodic deviation	+/- 0,7 μm
Resolution	0,0625 - 4 μm in connection with SMEa
Reproducibility	+/- 0,0625
Hysteresis	typically 0,25 μm

Movement

Max. speed	3 m/s
Max. acceleration	30 g

Environment

Protection class	IP 67
Operating temperature	0°-70° C
Storage temperature	-20°-70° C
Vibration / shock	30 g

Interfaces

analogue	Voltage interface 1 Vss, 11 μAss
digital	Square wave signals with error signal
Power supply	5 V +/- 0,25 V
Voltage current demand	40 mA per reading head

Dimensions MONORAIL

MR	L ₇ MRA/MRC	L ₇ MRB/MRD	L ₈	D	L ₉ MRA/MRC	L ₉ MRB/MRD
25	57	79,4	12	7	171,5	193,9
35	76	103	16,5	7	199,5	226
45	99,5	134,5	19	7	228	263
55	129,5	161,5	22	7	254	296
65	-	201	25	7	-	341,5

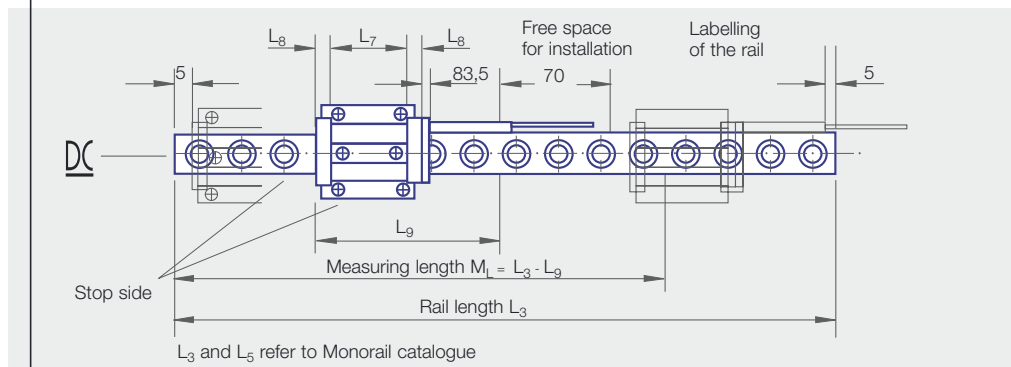

Option distance-coding

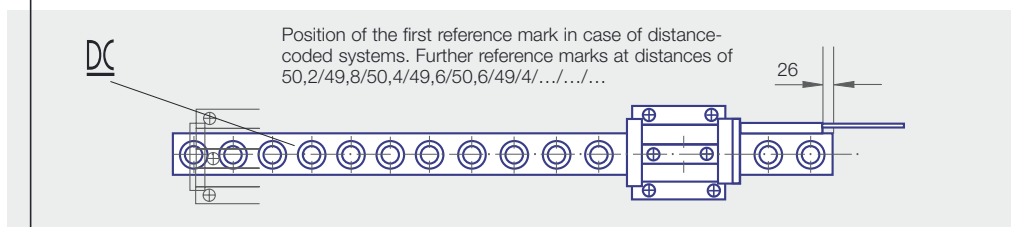

Option reference marks 50 mm spacing

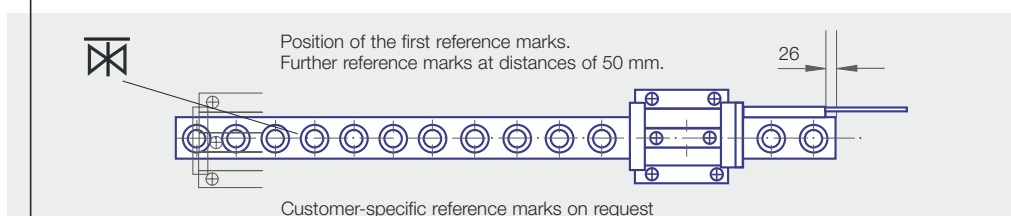

AMSA-30 Ordering information

	1 AMSA-30 - 25 - 948 - S - SU		
Number			
Type			
Size	25, 35, 45, 55, 65		
Length	in mm (magnetised length)		
Reference	S Reference points every 50 mm		
	C Distance-coded		
	K Customer-specific coding		
Cable	MU 0,3 m cable with mounting base (12-pole)		
Interface	SU 3 m Cable with plug-in connector 12-pole union nut		
	RU 3 m cable with plug-in connector 12-pole external thread		
	OO System is to be supplied without reading head.		

Spare parts / Reading heads

SMA-30-MU	580 101 836	Scanning unit	SMA-30-MU	0,3 m cable
SMA-30-SU	580 101 837	Scanning unit	SMA-30-SU	3 m cable
SMA-30-RU	580 101 836	Scanning unit	SMA-30-RU	3 m Kabel AG
NRP-DST	580 101 854	Replacement parts set of seals	AMSA-30	

Pin assignment AMSA 30, view onto the pin side

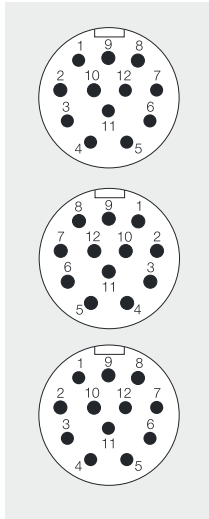

AMSA 30 with Mounting base (MU)	1	-Ue2
	2	Sensor +5 V
	3	Ue0
	4	-Ue0
	5	Ue1
	6	-Ue1
	7	
	8	+Ue2
	9	
	10	0 V (GND)
	11	Sensor 0 V
	12	+5 V (V _{CC})
	Housing	outside screen

Execution mounting base with flange socket

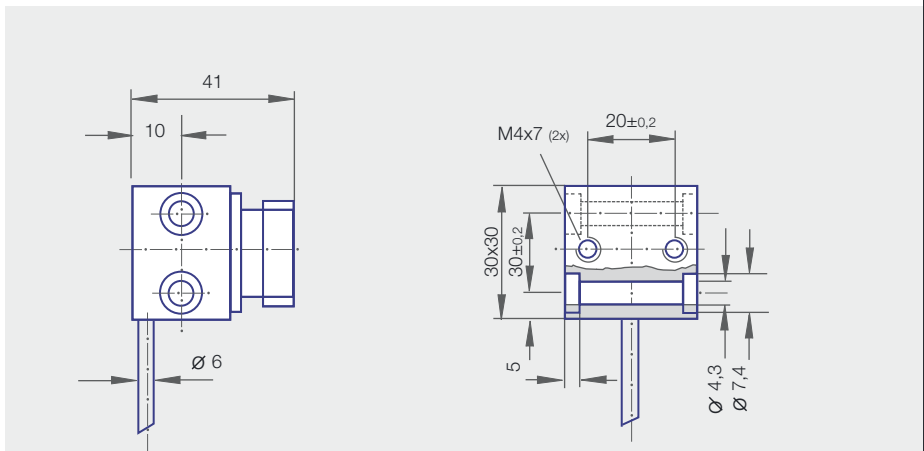

The MONORAIL System

Roller guideway with outstanding characteristics

- ___ Many years of experience in the application of roller guideways.
- ___ High rigidity for a great static – and dynamic load-bearing capacity.
- ___ High running quietness for better processing performances of the work-pieces.
- ___ Optimum sealing of the guide carriages against external influences.
- ___ Many and diverse possibilities for the distribution of the lubricant in the system.
- ___ Innovative solutions for covering the bores:
Plugs or covering strip MAC.

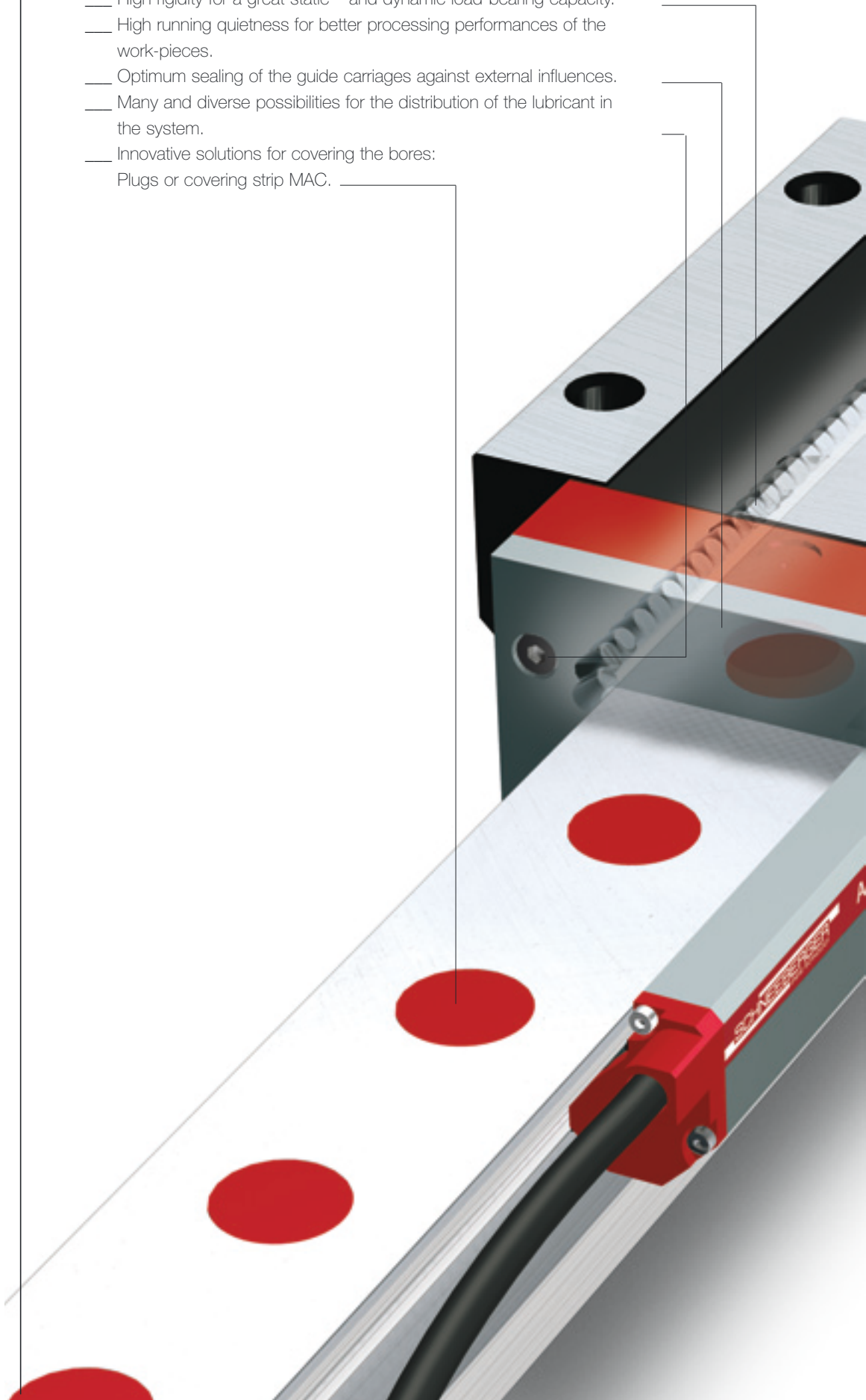

As a result of the combination of the high-precision MONORAIL system with the specially applied measuring principle, you achieve qualities, which enable compact installation. These qualities do not have to be achieved by installation and adjustment, because SCHNEEBERGER supplies these qualities as immanent to the system.

As a result, you save process costs in the design and construction, manufacture and maintenance of your products. You have at your disposal a high degree of safety with respect to the system function. SCHNEEBERGER with this makes possible a reduction of the complexity. The system is modularly utilisable, because it is based upon on the MONORAIL technology.

The accuracy is produced mechanically independently by the measuring principle. Therefore you have the possibility of changing the individual components without any adjustment. For you this signifies a minimisation of the process costs during the installation and in maintenance, e.g., a reduction of the machine down times.

The measuring principle utilised and the modular design of the system provides you with the possibility of participating in the continuous development of the measuring system and of continually maintaining the value in use.

As technology leader of the linear technology sector, SCHNEEBERGER is predestined to be in a position over and above solely linear distance measuring of supplying unique integrated solutions of linear distance measurement. Strategic system thinking at SCHNEEBERGER leads to products with a high efficiency for the user.

The MONORAIL AMS complete package

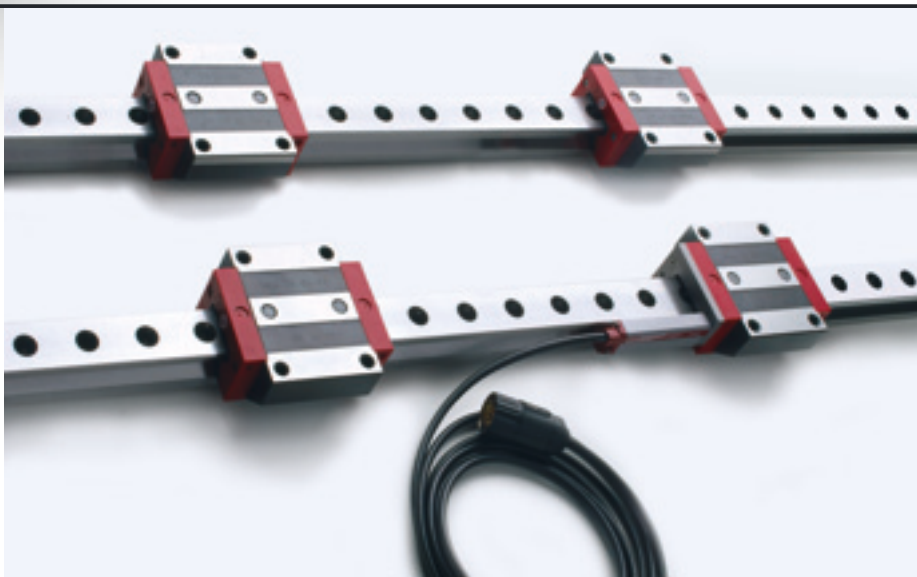

The W.Schneeberger AG company was founded in 1923 with its main operating base in Switzerland. Today there are five subsidiary companies dotted around the globe. The production sites are in Switzerland and in Germany. Using a global network of sales companies and exclusive distribution outlets, SCHNEEBERGER supplies more than 4000 customers in all the major industrial nations.

More than 50 years ago, SCHNEEBERGER laid the foundation for today's global linear technology with its linear guideways. The range of products constructed on a modular basis provides solutions for the widest possible series of applications: linear guideways, roller gear tables, MONORAIL and MINIRAIL profiled track guideways, MONORAIL AMS mechatronics guideways, positioning systems. SCHNEEBERGER assigns great importance to customer support – especially in the project management and planning phases. Detailed calculations and analyses allow solutions to be found for every application.

SCHNEEBERGER is fully committed to the further development of its products and range of goods and to improving its manufacturing infrastructure and logistics, so as to be able to meet the most demanding requirements in the future with economical and reliable products.

SWITZERLAND	W.Schneeberger AG · 4914 Roggwil/BE Phone 062 918 41 11 · Fax 062 918 41 00 · info-ch@schneeberger.com
ITALY	Schneeberger S.p.A. · 21021 Angera VA Phone 0331 93 20 10 · Fax 0331 93 16 55 · info-i@schneeberger.com
GERMANY	Schneeberger GmbH · 75339 Höfen/Enz Phone 0 70 81 782-0 · Fax 0 70 81 782-124 · info-d@schneeberger.com
FRANCE	Schneeberger Technique Linéaire · 91222 Brétigny-sur-Orge Cedex Phone 01 69 88 50 00 · Telefax 01 60 84 96 02 · info-f@schneeberger.com
USA	Schneeberger Inc. · Bedford, MA 01730 Phone 781-271-0140 1-800-854-6333 · Fax 781-275-4749 · info-usa@schneeberger.com
INTERNET	www.schneeberger.com