

POWER TRANSMISSION



Differential Roller Screws

Nominal Diameter 8 - 25 mm



The company **Steinmeyer** was established in 1920, and was originally concerned exclusively with the production of precision measuring instruments.

Over 30 years ago, a second line was launched with the development of what was then an almost unknown technology: the ballscrew and nut assembly, now the company's most important product line.

In cooperation with the German Aerospace Center (DLR) **Steinmeyer** developed further the Differential Roller Screw (DRS).

The structural design of a DRS provides for a very cost-effective solution even for demanding requirements regarding efficiency and load capacity.

Experience and flexibility, as well as continually updated production facilities have made the name **Steinmeyer** synonymous with quality and reliability the world over. The company's continued expansion reflects the success of our close cooperation with our customers.

Specifications are subject to change without notice.

Other product names mentioned in this catalog may be trademarks or registered trademarks of their respective companies and are acknowledged hereby.

Reproduction is prohibited without the express written permission of

August Steinmeyer GmbH & Co. KG

Copyright © 08/2000

Printed in Germany

Design Features

Planetary Roller Screws offer high load capacities for rotary-to-linear power transmission, or vice versa.

Compared to conventional planetary roller screws, **Steinmeyer** DRS feature also very high speed capability, along with affordable price and flexibility in design. They are compact, yet reliable, and can be used in a variety of applications to meet low-cost as well as high precision requirements.

The basic principle, as developed at the German Aerospace Center (DLR) (<http://www.dlr.de>), features a threaded spindle with a set of rollers and a nut. Rollers transmit thrust from spindle to nut through rolling contact, thus minimizing friction and wear. Rollers orbit at constant speed while in uninterrupted contact with nut and spindle. A patented feature allows combinations of fine pitch and coarse pitch independently, and even combinations of left hand and right hand threads in the same unit. Therefore, the feed rate per revolution is no longer identical to the lead of the threaded spindle.

Design

The Differential Roller Screw consists of spindle, circulating rollers and the nut (fig. 1).

Fig. 1

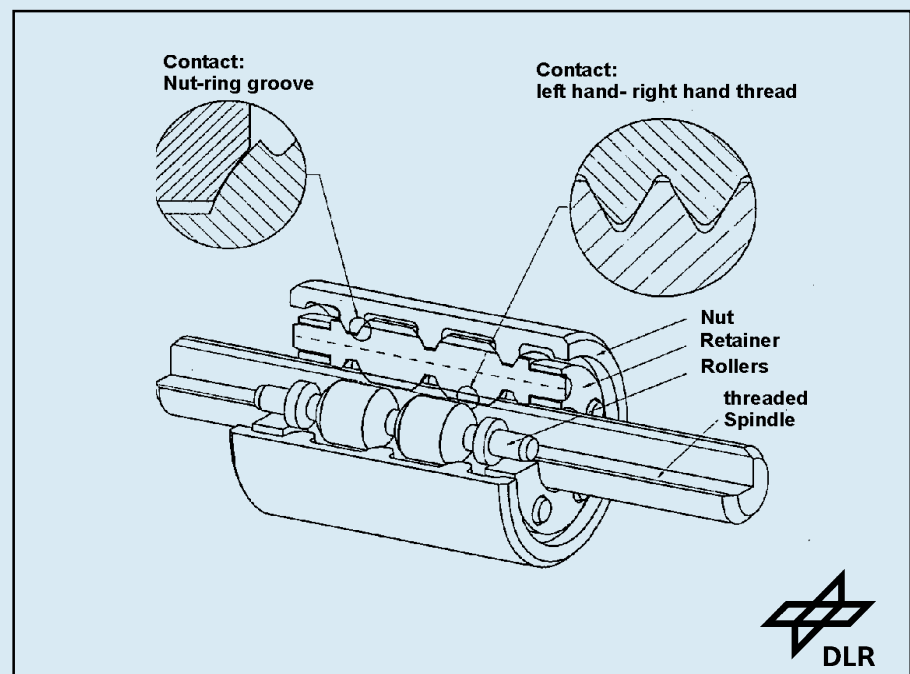

Fig. 1 Design example with fine pitch threads on spindle and rollers, and coarser pitch circular grooves between rollers and nut for high gear ratio. This type of differential roller screw was used in the gripper of the ROTEX robot flown with the NASA D2 Spacelab mission.

Courtesy of DLR

Efficiency

Due to rolling friction the efficiency of a DRS is substantially higher compared to normal trapezoidal threaded screws.

Fig. 2

Fig. 2 shows, that efficiency of a ballscrew is again higher compared to the DRS.

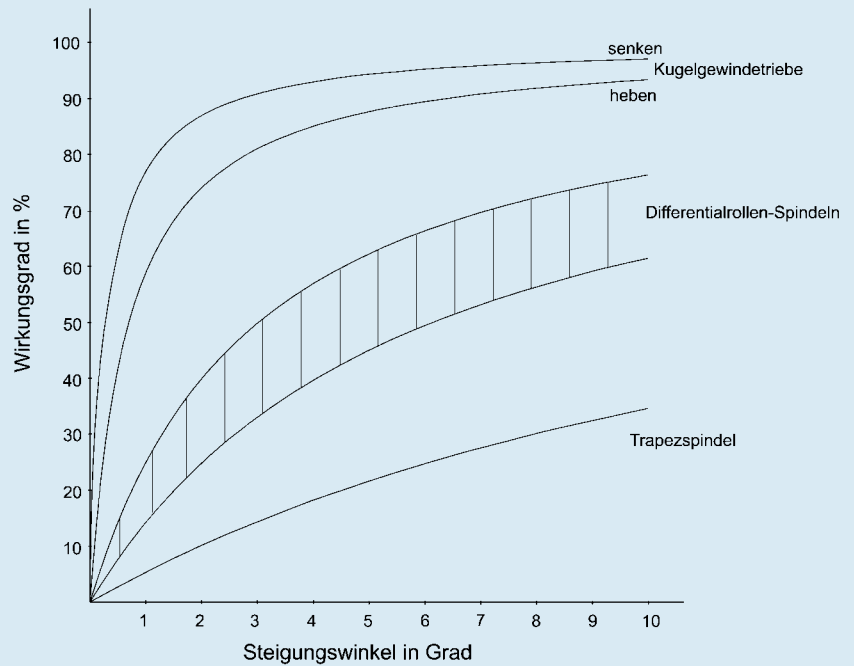

Materials

Steinmeyer DRS can be designed to meet various applications. Parts can be made from plastic material for low-cost applications, or from hardened and ground steel to meet most demanding requirements. Their simplicity in design allows for tight manufacturing tolerances.

Fig. 3

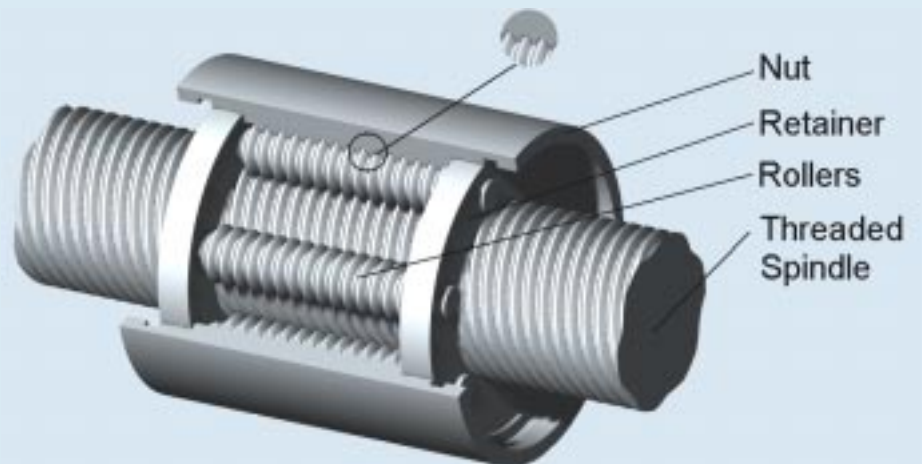
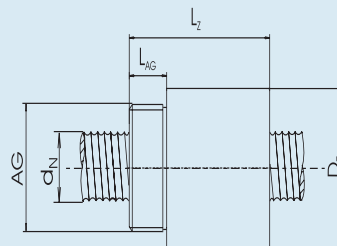

Fig. 3 DRS with threaded rollers

Different Profiles

Furthermore, selecting spindle and roller diameters makes it possible to change gear ratios, just like in a planetary reduction gear. Feed per revolution can be as small as 0.5 mm or even below. And design options include high output lead as well. Thus, this truly unique feed screw offers design flexibility unavailable in other screw drives. With the **Steinmeyer** DRS, designers have an unprecedented choice of selecting fast or slow linear output.

Fig. 4



The following main properties result from different profiles of rollers and nut:

Table 1

	Type A Fine pitch screw, coarse pitch nut	Type B Fine pitch screw, fine pitch nut
High thrust through high reduction ratio, small effective lead	++	-
Fast feed rate through large lead	-	++
High efficiency	+	++
Increased reliability through absence of critical parts	+	++
Smooth, quiet operation	+	++
Low wear and heating	++	++
Easy installation, nut can be removed and installed in-field	+	++
Robust construction	+	++
Low cost	+	++

Applications

Even extreme requirements regarding input speeds (up to several 10,000 rpm), gear ratios (0.5 mm effective lead and below), clearance (optional zero or even preloaded), and load capacities can be met. Absence of any complicated gearing, roller deflectors and other critical parts make **Steinmeyer** DRS the choice whenever performance, reliability, and low cost is demanded.

Through their unequalled design flexibility **Steinmeyer** DRS can often eliminate reduction gearboxes. They can be driven at almost any input speed and will still meet output force and speed requirements.

Through their relatively low surface pressure **Steinmeyer** DRS offer high load capacities, rigidity, and low heating. Backlash-free units are available.

Lubrication

Steinmeyer DRS should be lubricated with grease only. Suitable is any roller bearing grease. Standard grease is "Klüber Staburags NBU8EP". For re-lubrication we suggest mineraloil-based lithium or barium grease. Please note, that especially short strokes and oscillating loads require an optimum lubrication.

The use of DRS for extreme applications like temperatures below -20°C / over 100°C , vacuum, radiation, cleanroom and aerospace should be discussed with our engineers.

Journals

Generally, in mechanical engineering bearings with similar stiffness values than the screws itself, should be used. Sizes of the bearings are determined by the screw diameter, as this diameter very often is used as bearing shoulder.

Bearing Configuration

Axial Stiffness and critical rpm of a DRS can be increased by using fixed-fixed bearing configuration. Please note, that on at least one end the journal diameter should not exceed the core diameter of the ballthread to make sure that it is still possible to assemble the nut.

Using shrunk collars on both ends means disassembling the nut is no longer possible, which will cause high costs in case of repair.

Accuracy

In opposite to other screws drives, on DRS the rotation of the screw and the axial position of the nut do not clearly match!

The lead of the whole system is not the lead of the screw itself, but is also determined by the different diameters of screw and rollers.

Positioning

The rollers work under "rolling friction" to the screw and to the nut. This fact causes a certain lost motion. Therefore there is no repeatability of the feed. In case of repeatability is required, we are in need of an additional measuring system! On most applications, two end switches will solve that problem.

Nut-unit with fine pitch thread on nut and rollers



Fig. 5

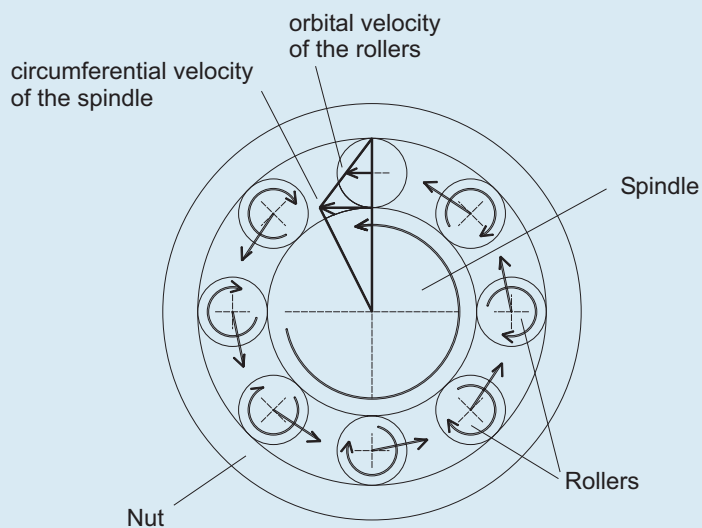
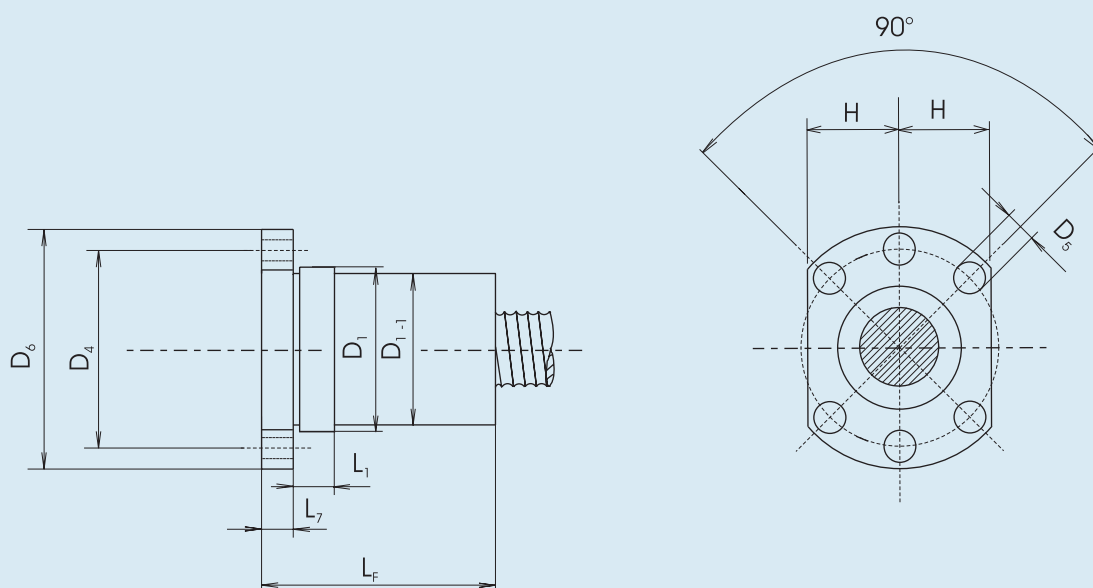

Fig. 2 Relative speeds. For simplicity, pitch circle diameter shown only.



Series	Lead P [mm]	Nominal Diameter d_N [mm]	Dyn. Load Rating C_a [kN]	Stat. Load Rating C_{0a} [kN]	Flange Type
7412/7112	1	8	1,9	3,8	1
	2,5	8	1,5	2,1	1
	4	12	5,2	7,2	1
7416	5	16	7,6	10,6	2
	10	25	36,0	50,0	2

Nut Type 7416



Serie 7412:
Flange-Type

Serie7416:
Flange-Type acc. to standard KGT-DIN 69051

Serie 7112:
Cylindrical Type with Connection Thread

Series with Flanged Nut									Series with Connection Thread			
L _F	D ₁ g6	L ₁	D ₄	D ₅	D ₆	L ₇	H		L _Z	D _Z	AG	L _{AG}
[mm]	[mm]	[mm]	[mm]	[mm]	[mm]	[mm]	[mm]	[mm]	[mm]	[mm]	[mm]	[mm]
38	25	-	35	5,5	44	10	14,5		47	25,5	M20x1	10
16	16	-	22	3,4	28	6	9,5		23,5	17,5	M15x1	7,5
25	28		38	5,5	48	10	15,5		34	25,5	M20x1	10
31	36	10	47	6,6	58	10	22		42	32,5	M26x1,5	12
60	40	10	51	6,6	62	10	24		80	44	M40x1,5	17,5

Nut Type 7412

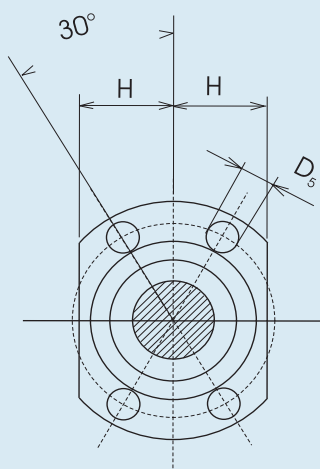

Nut Type 7112

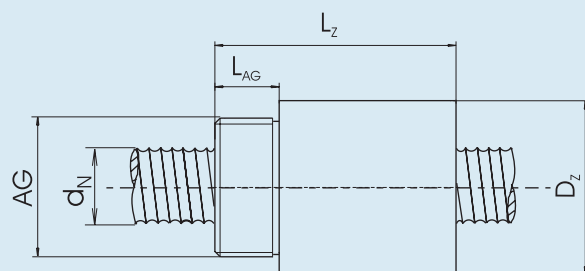

General Information

Why Differential Screw?

The set of rollers is driven by the screw, following it at reduced speed as determined by their diameter ratio. While rollers maintain their axial position relatively to the nut, they still orbit. One of the possible design options features circular grooves interacting with the threads on the spindle. In this case effective feed per revolution is reduced through the rollers' relative speed in relation to the spindle- the spindle advances slower than it would normally. The spindle "sees" a slower relative speed between its threads and the corresponding circular grooves of the rollers.

Other design options include threads on the rollers to interact with the spindle. This adds an axial component of the motion. Even combinations of left hand threads on the spindle, and right hand threads on the rollers are possible, allowing almost any effective lead of the unit.

Application Possibilities

In many cases there is no need of an exact positioning, apart from end-switches.

For example:

- actuators for valves in air conditioners
- gear jacks in medicine technical devices
- valve adjusty devices

DRS also can be used on drives which are controlled via force, rpm, or speed without problems.

For example:

- brakes for cars (controlled by wheel rpm)
- turbocharger-wastegate adjustment (controlled by pressure)
- mixing devices (controlled by temperature)

Linear drives with high repeatability

Also for high demanding positioning drives DRS are applicable. Due to smooth running even on high rpm, a wide range of speed is achievable. There are even high cost savings when using small lead DRS as transmission gears, expensive stepper motors and rotational transmitters are no longer required.

Economy

Also for moving and positioning drives which are restricted in space or power requirements, DRS can be used.

- replacement of hydraulic and pneumatic cylinders
- applications where expensive ballscrews cannot be replaced by leadscrews (due to poor efficiency) but by DRS.
- application on motor driven movement devices, when a smooth, long life, maintenance free and reliable operation with high efficiency is required.

